



400mA , Ultralow Output Voltage 0.8V, Adjustable ,High Speed LDO ME6222 Series

General Description

The ME6222 series are highly accurate, low noise, LDO Voltage Regulators .The output voltage can be set via the external resistor. On chip trimming adjusts the reference/output voltage to within $\pm 2\%$ accuracy. Internal protection features consist of output current limiting, safe operating area compensation, and thermal shutdown. The current limiter's feedback circuit also operates as a short protect for the output current limiter and the output pin. The CE function allows the output of regulator to be turned off, resulting in greatly reduced power consumption. The ME6222 series can operate with up to 18V input.

Features

- Voltage Setting via External Resistor: 0.8V~5.0V
- Maximum Output Current: 400mA
- Dropout Voltage:
125mV@ $I_{OUT} = 100mA$ ($V_{out} = 3.3V$)
- Operating Voltage Range: 2.8V~18V
- Highly Accuracy: $\pm 2\%$
- Standby Current: 45uA (TYP.)
- Line Regulation: 30mV (TYP.)
- Temperature Stability $\leq 0.5\%$
- Thermal Shutdown Protection: 165°C

Applications

- Consumer and Industrial Equipment Point of Regulation
- Switching Power Supply Post Regulation
- Hard Drive Controllers
- Battery Chargers

Package

- 5-pin SOT23-5



Typical Application Circuit

ME6222

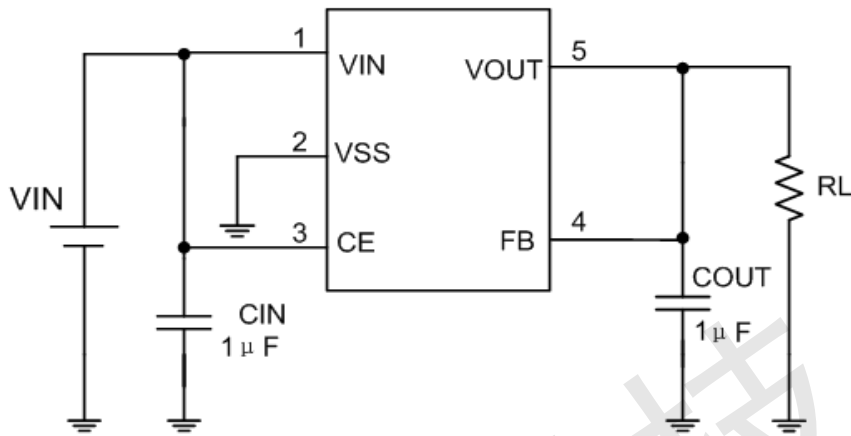

Fig.1 $V_{OUT}=V_{FB}=0.8V$

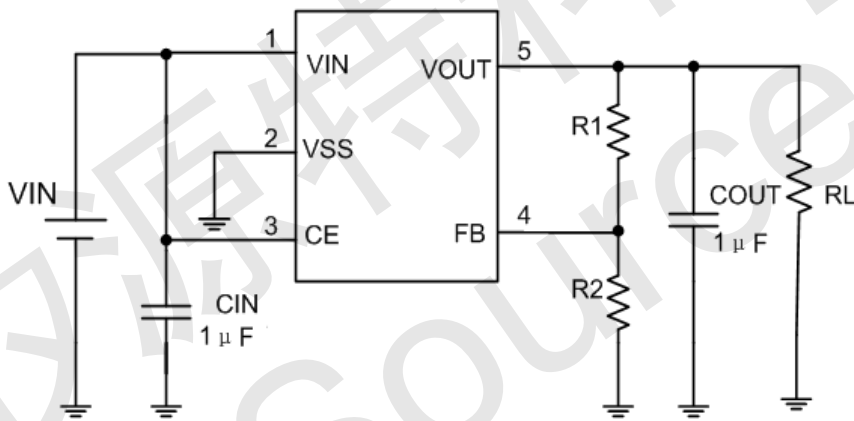

Fig.2 $V_{OUT}=0.8X(R1+ R2)/R2$



Selection Guide

ME6222

ME 6222X X X G

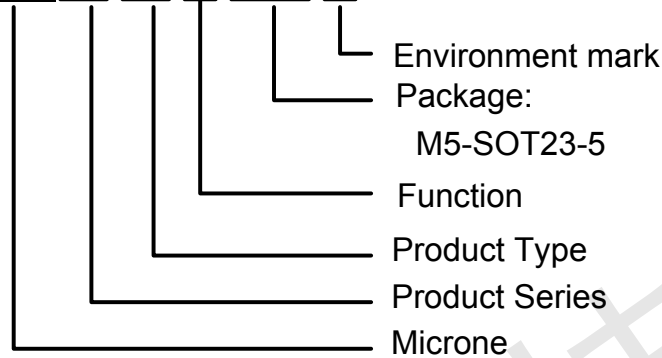

product series	product description
ME6222CM5G	$V_{FB} = 0.8V$, the output voltage is adjustable

Pin Configuration

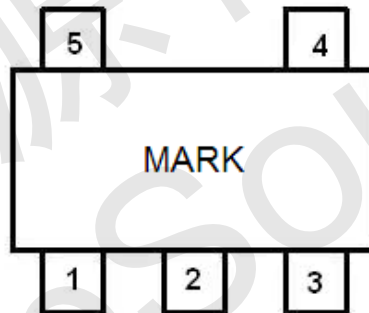

SOT23-5

Pin Assignment

Pin Number	Pin Name	Functions
SOT23-5		
1	V_{IN}	Power Input Voltage
2	V_{SS}	Ground
3	CE	ON / OFF Control
4	FB	Feedback Voltage
5	V_{OUT}	Output Voltage



Block Diagram

ME6222

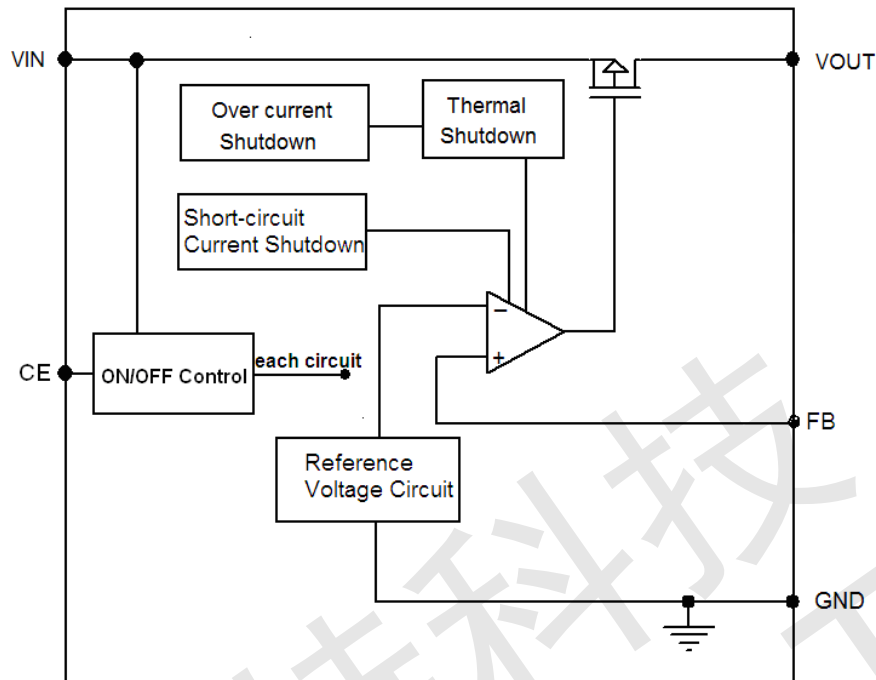

Absolute Maximum Ratings

Parameter	Symbol	Ratings	Units
Input Voltage	V_{IN}	18	V
Output Current	I_{OUT}	500	mA
Output Voltage	V_{OUT}	$V_{SS}-0.3\sim 8.0$	V
CE Pin Voltage	V_{CE}	$V_{SS}-0.3\sim V_{IN}+0.3$	V
FB Pin Voltage	V_{FB}	$V_{SS}-0.3\sim V_{IN}+0.3$	V
Power Dissipation	SOT23-5 P_D	300	mW
Operating Temperature Range	T_{OPR}	$-40\sim +150$	$^{\circ}C$
Storage Temperature Range	T_{STG}	$-55\sim +150$	$^{\circ}C$
Lead Temperature		$260^{\circ}C, 4sec$	



Electrical Characteristics

ME6222

($V_{IN}=V_{OUT}+1$, $V_{CE}=V_{IN}$, $V_{OUT}=V_{FB}$, $C_{IN}=C_{OUT}=1\mu F$, $T_a=25^{\circ}C$, unless otherwise noted)

Parameter	Symbol	Conditions	Min.	Typ.	Max.	Units
Feedback Voltage	V_{FB}	$I_{OUT}=30mA$,	784	800	816	mV
Output Voltage Range	$V_{OUT}(E)$ (Note 2)	$V_{IN}=V_{OUT}(T)+1V$, $V_{CE}=V_{IN}$ Using test circuit 2	0.8		5.0	V
Maximum Output Current	I_{OUTMAX}	$V_{IN}=V_{OUT}+1V$ (Note1)		400	550	mA
Load Regulation	ΔV_{OUT}	$1mA \leq I_{OUT} \leq 100mA$		4	10	mV
Dropout Voltage (Note 3)	V_{DIF1}	$I_{OUT}=100mA$		125	140	mV
	V_{DIF2}	$I_{OUT}=200mA$		250	270	mV
Supply Current	I_{SS}	$V_{IN}=3V$, $V_{CE}=V_{IN}$		45	60	μA
Stand-by Current	I_{CEL}	$V_{IN}=3V$, $V_{CE}=0V$		0	1	μA
Line Regulation (Note 1)	ΔV_{OUT}	$I_{OUT}=30mA$ $V_{OUT}+1V \leq V_{IN} \leq 18V$		4	15	mV
CE "High" Voltage	V_{CEH}	$RL=1.0K\Omega$	1.3		18	V
CE "Low" Voltage	V_{CEL}	$RL=1.0K\Omega$	0		0.7	V
CE "High" Current	I_{SH}	$V_{CE}=7V$	-0.1		0.1	μA
CE "Low" Current	I_{SL}	$V_{CE}=0V$	-0.1		0.1	μA
Short-circuit Current	I_{SHORT}	$V_{OUT}=0V$		70		mA
Thermal Shutdown Protection	T_{sd}	$I_{OUT}=1mA$,		165		$^{\circ}C$
Over Current Protection	I_{limit}			600		mA

Note :

- $V_{OUT}(T)$: Output Voltage less than 0.8V, the input Voltage should be 2.8V at least, and the others fulfil the rule of $V_{in}=V_{out}+1$.
- $V_{OUT}(E)$: Effective Output Voltage (i.e. The output voltage when " $V_{OUT}(T)+1.0V$ " is provided at the V_{in} pin while maintaining a certain I_{OUT} value.)
- V_{DIF} : $V_{IN1}-V_{OUT}(E)'$
 V_{IN1} : The input voltage when $V_{OUT}(E)'$ appears as input voltage is gradually decreased.
 $V_{OUT}(E)'$: A voltage equal to 98% of the output voltage whenever an amply stabilized I_{OUT} { $V_{OUT}(T)+1.0V$ } is input.



Type Characteristics

(1) Output Voltage VS. Output Current
($V_{IN}=V_{OUT}+1V$, $V_{OUT}=3.3V$)

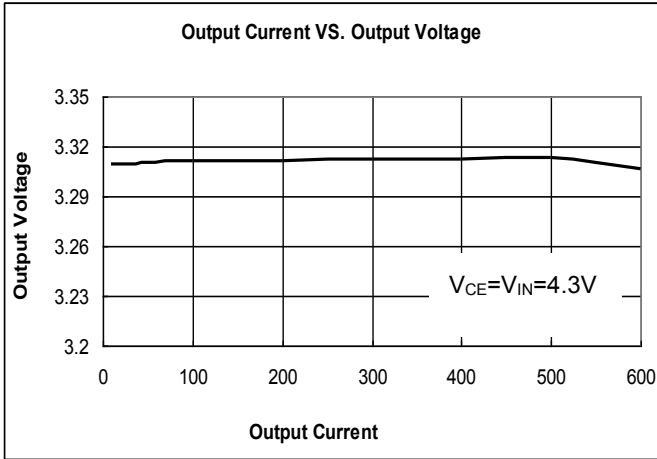

(2) Output Voltage VS. Temperature
($V_{IN}=V_{OUT}+1V$, $V_{OUT}=3.3V$, $I_{OUT}=10mA$)

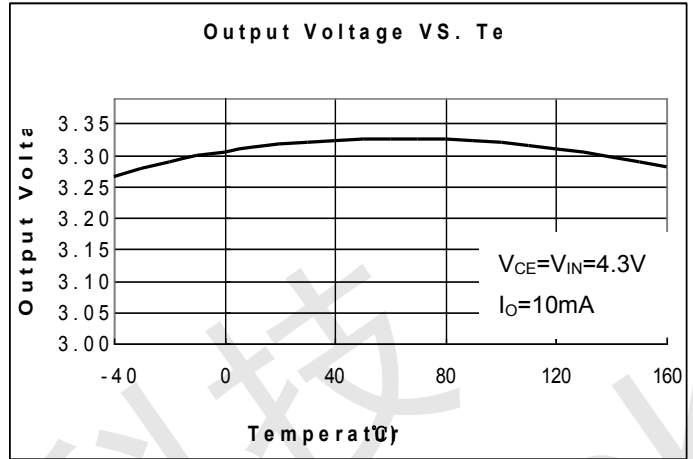

(3) Dropout Voltage VS. Output Current
($V_{IN}=V_{OUT}+1V$, $V_{OUT}=3.3V$)

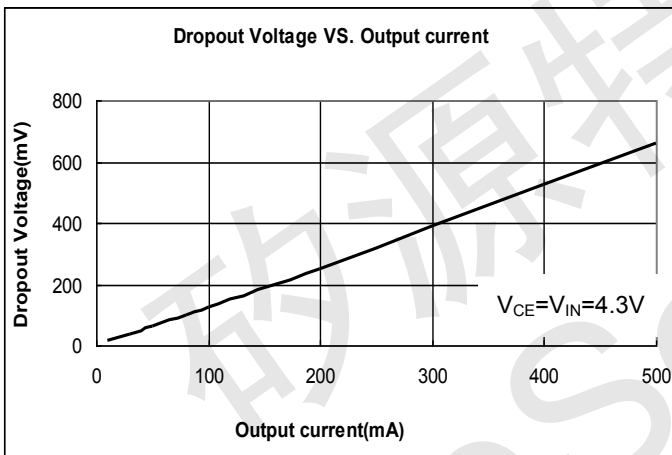

(4) Output Voltage VS. Input Voltage
($V_{OUT}=3.3V$)

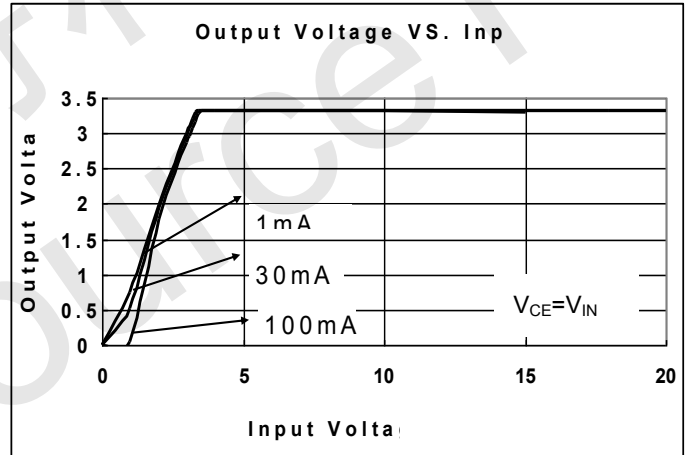

(5) Quiescent Current VS. Input Voltage

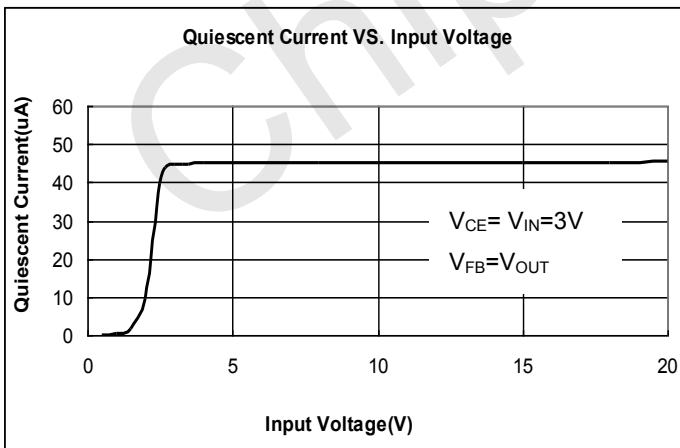



Applications Information

ME6222

1. Setting the Output Voltage

ME6222 series output voltage can be set via a external resistor. AS the internal reference is 0.8V (Typical), the external voltage can optionally set between 0.8V and 5.0V by connecting a extra resistor between the Vout and V_{FB} pins and a resistor between the V_{FB} and V_{SS} pins.

The output voltage is calculated as below:

$$V_{OUT}=0.8x(1+R1/R2)$$

Table 1: Resistor selection for output voltage setting (e.g.)

V _o (V)	R1 (KΩ)	R2 (KΩ)
1.2	50	100
1.8	125	100
2.5	215	100
3.0	275	100
3.3	315	100
3.6	350	100
5.0	525	100

Caution: The value of R2 is more than 100K in the best.

2. Input Bypass Capacitor

An input capacitor is recommended. A 1uF or more tantalum on the input is a suitable input bypassing for almost all applications.

3. Output Capacitor

The output capacitor is critical in maintaining regulator stability, and must meet the required conditions for both minimum amount of capacitance and ESR (Equivalent Series Resistance).The output capacitance required by the ME6222 is 2.2μF or more, If a tantalum capacitor is used. Any increase of the output capacitance will merely improve the loop stability and transient response. The ESR of the output capacitor should be less than 1Ω .

4. Load Regulation

The ME6222 regulates the voltage that appears between its output and adjust pins. In some cases, line resistances can introduce errors to the voltage across the load. To obtain the best load regulation, a few precautions are needed. Figure 1, shows a typical application. The R_{t1} and R_{t2} are the line resistances. It is obvious that the V_{LOAD} is less than the V_{OUT} by the sum of the voltage drops along the line resistances. In this case, the load regulation seen at the R_{LOAD} would be degraded from the datasheet specification. To improve this , the load should be tied directly to the output terminal on the positive side and directly tied to the ground terminal on the negative side.

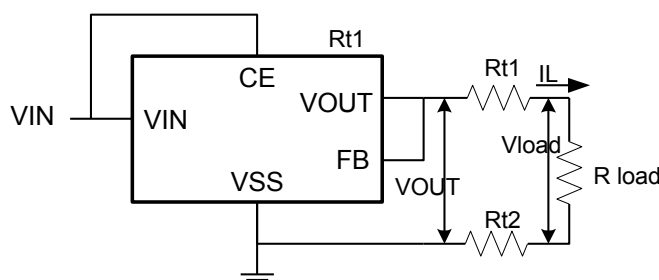

$$V_{load}=V_{OUT}-I_L(R_{t1}+R_{t2})$$

Fig.1 Typical Application



Packaging Information

ME6222

- Packaging Type: SOT23-5

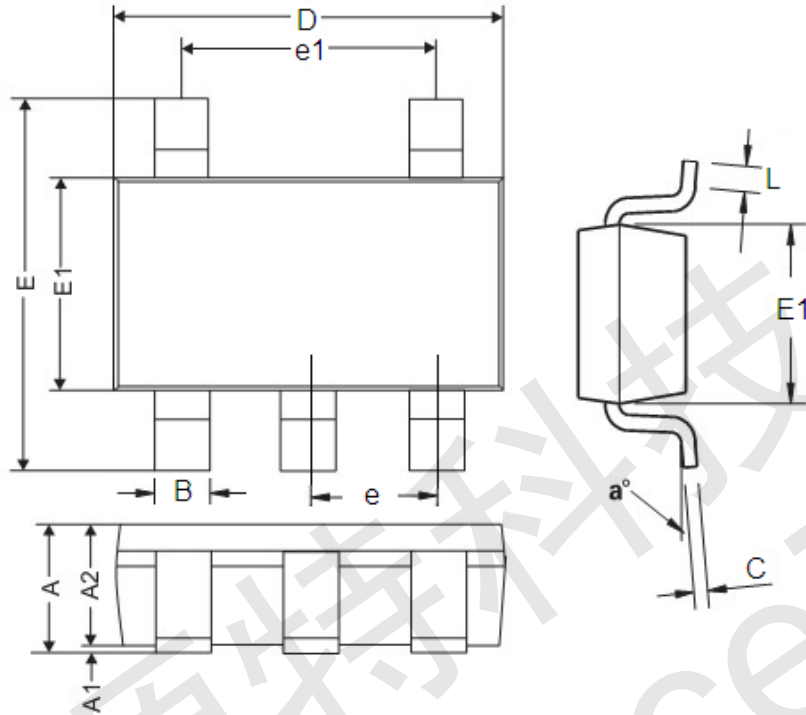

DIM	Millimeters		Inches	
	Min	Max	Min	Max
A	0.9	1.45	0.0354	0.0570
A1	0	0.15	0	0.0059
A2	0.9	1.3	0.0354	0.0511
B	0.2	0.5	0.0078	0.0196
C	0.09	0.26	0.0035	0.0102
D	2.7	3.1	0.1062	0.1220
E	2.6	3.1	0.0866	0.1181
E1	1.50	1.80	0.0511	0.0708
e	0.95REF		0.0374REF	
e1	1.90REF		0.0748REF	
L	0.10	0.60	0.0039	0.0236
a ⁰	0 ⁰	30 ⁰	0 ⁰	30 ⁰



- The information described herein is subject to change without notice.
- ShenZhen ChipSourceTek Technology Co.,Ltd. is not responsible for any problems caused by circuits or diagrams described herein whose related industrial properties, patents, or other rights belong to third parties. The application circuit examples explain typical applications of the products, and do not guarantee the success of any specific mass-production design.
- Use of the information described herein for other purposes and/or reproduction or copying without the express permission of ShenZhen ChipSourceTek Technology Co.,Ltd. is strictly prohibited.
- The products described herein cannot be used as part of any device or equipment affecting the human body, such as exercise equipment, medical equipment, security systems, gas equipment, or any apparatus installed in airplanes and other vehicles, without prior written permission of ShenZhen ChipSourceTek Technology Co.,Ltd..
- Although ShenZhen ChipSourceTek Technology Co.,Ltd. exerts the greatest possible effort to ensure high quality and reliability, the failure or malfunction of semiconductor products may occur. The user of these products should therefore give thorough consideration to safety design, including redundancy, fire-prevention measures, and malfunction prevention, to prevent any accidents, fires, or community damage that may ensue.