



MT2445AD 0.8A,40V Input,600kHz Synchronous Step-Down Converter

MT2445AD FEATURES

- High Efficiency at 12 In 3.3V Out Up to 92%
- 600KHz Frequency Operation
- 0.8A Output Current
- No Schottky Diode Required
- 5V to 40V Input Voltage Range
- 0.8V Reference
- Slope Compensated Current Mode Control for Excellent Line and Load Transient Response
- Integrated internal compensation
- Stable with Low ESR Ceramic Output Capacitors
- Thermal Shutdown and UVLO
- Inrush Current Limit and Soft Start
- Available in SOT23-6 Package
- -40°C to +85°C Temperature Range

MT2445AD APPLICATIONS

- Small Meters
- Industrial Applications
- Automotive Applications
- Flat Panel Television and Monitors
- Wireless and DSL Modems
- Notebook Computer

MT2445AD TYPICAL APPLICATION

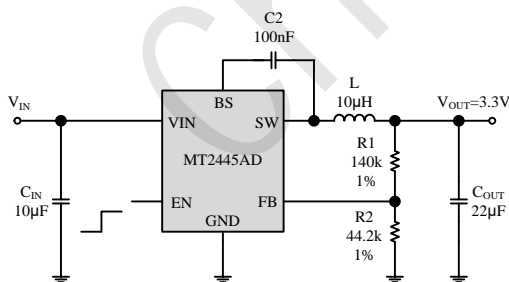

Figure 1. Basic Application Circuit

MT2445AD GENERAL DESCRIPTION

The MT2445AD is a wide input range, high-efficiency, synchronous step-down switching regulator, capable of delivering up to 0.8A of output current. With a fixed switching frequency of 600KHz, this current mode PWM controlled converter allows the use of small external components, such as ceramic input and output caps, as well as small inductors.

MT2445AD also employs a proprietary control scheme that switches the device into a power save mode during light load, thereby extending the range of high efficiency operation. making it an ideal solution for industrial applications such as smart meters as well as automotive applications. In automotive systems, power comes from the battery, with its voltage typically between 9V and 24V. Including cold crank and double battery jump-starts, the minimum input voltage may be as low as 5V and the maximum up to 40V, with even higher transient voltages. With these high input voltages, linear regulators cannot be used for high supply currents without overheating the regulator. Instead, high efficiency switching regulators such as MT2445AD must be used to minimize thermal dissipation.

MT2445AD is available SOT23-6 Packages.



MT2445AD 0.8A,40V Input,600kHz Synchronous Step-Down Converter

MT2445AD ABSOLUTE MAXIMUM RATINGS (Note 1)

Input Supply Voltage.....	-0.3V to 45V	Thermal Resistance θ_{JA}	170°C/W
EN Voltages.....	-0.3V to 45V	Junction Temperature(Note2).....	150°C
FB Voltages.....	-0.3V to 6V	Operating Temperature Range.....	-40°C to 85°C
SW Voltage.....	-0.3V to ($V_{IN}+0.5V$)	Lead Temperature(Soldering,10s).....	300°C
BS Voltage.....	($V_{SW}-0.3V$) to ($V_{SW}+5V$)	Storage Temperature Range.....	-65°C to 150°C
Power Dissipation.....	0.6W	ESD HBM(Human Body Mode).....	2kV
Thermal Resistance θ_{JC}	130°C/W	ESD MM(Machine Mode).....	200V

MT2445AD PACKAGE/ORDER INFORMATION

	Order Part Number	Package	Top Marking
	MT2445AD	SOT23-6	A06VDC

V: version, D:year, C:week

MT2445AD PIN DESCRIPTION

Pin Name	Pin Number	Description
BS	1	Bootstrap. A capacitor (100nF) connected between SW and BS pins is required to form a floating supply across the high-side switch driver.
GND	2	Analog ground pin.
FB	3	Adjustable version feedback input. Connect FB to the center point of the external resistor divider.
EN	4	Drive this pin to a logic-high to enable the IC. Drive to a logic-low to disable the IC and enter micro-power shutdown mode.
VIN	5	Power supply Pin
SW	6	Switching Pin

MT2445AD ELECTRICAL CHARACTERISTICS (Note 3)

($V_{IN}=12V$, $V_{OUT}=3.3V$, $T_A = 25^\circ C$, unless otherwise noted.)

PARAMETER	CONDITIONS	MIN	TYP	MAX	UNIT
Input Voltage Range		5		40	V
Supply Current in Operation	$V_{EN}=2.0V$, $V_{FB}=1.1V$		0.4	0.6	mA



MT2445AD 0.8A,40V Input,600kHz Synchronous Step-Down Converter

PARAMETER	CONDITIONS	MIN	TYP	MAX	UNIT
Supply Current inShutdown	$V_{EN} = 0$ or $EN = GND$		2	10	μA
Regulated Feedback Voltage	$T_A = 25^{\circ}C, 5V \leq V_{IN} \leq 40V$	0.784	0.8	0.816	V
High-Side Switch On-Resistance			400		m Ω
Low-Side Switch On-Resistance			250		m Ω
High-Side Switch Leakage Current	$V_{EN} = 0V, V_{SW} = 0V$		0	10	μA
Upper Switch Current Limit	Minimum Duty Cycle		2		A
Oscillation Frequency			0.6		MHz
Maximum Duty Cycle	$V_{FB} = 1V$		92		%
Minimum On-Time			80		nS
Soft-start Time	T_{SS}		1		mS
Thermal Shutdown			160		$^{\circ}C$

Note 1: Absolute Maximum Ratings are those values beyond which the life of a device may be impaired.

Note 2: T_J is calculated from the ambient temperature T_A and power dissipation P_D according to the following formula: $T_J = T_A + (P_D) \times (170^{\circ}C/W)$.

Note 3: 100% production test at $+25^{\circ}C$. Specifications over the temperature range are guaranteed by design and characterization.



MT2445AD 0.8A,40V Input,600kHz Synchronous Step-Down Converter

MT2445AD TYPICAL PERFORMANCE CHARACTERISTICS

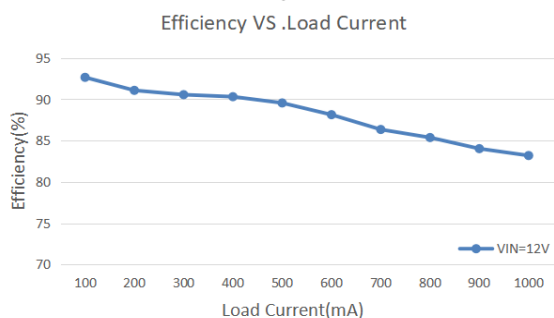

IN:12V,OUT:3.3V

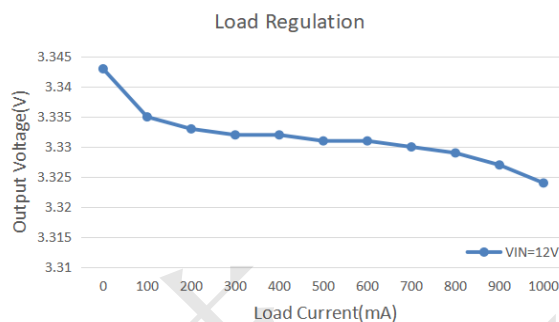

IN:12V,OUT:3.3V

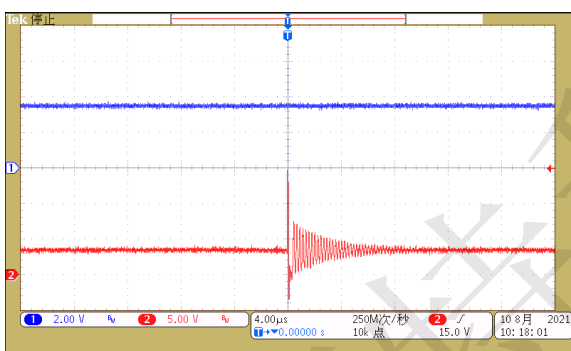

IN:12V,OUT:3.3V/0A

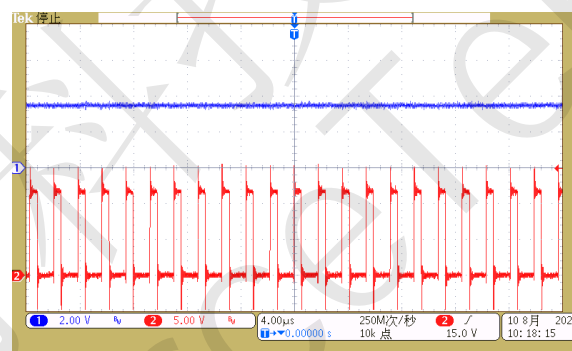

IN:12V,OUT:3.3V/0.8A

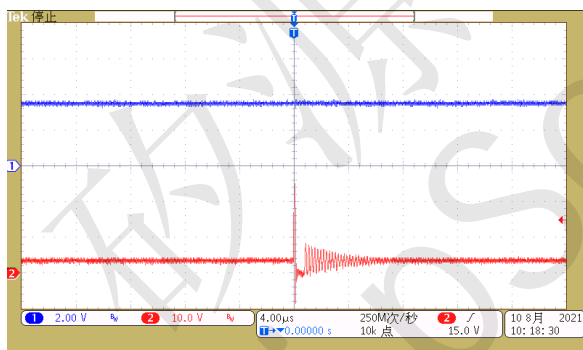

IN:24V,OUT:3.3V/0A

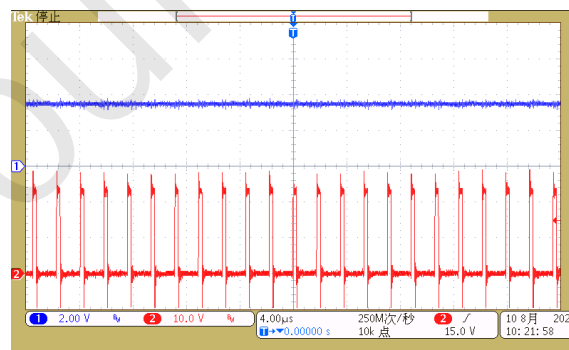

IN:24V,OUT:3.3V/0.8A

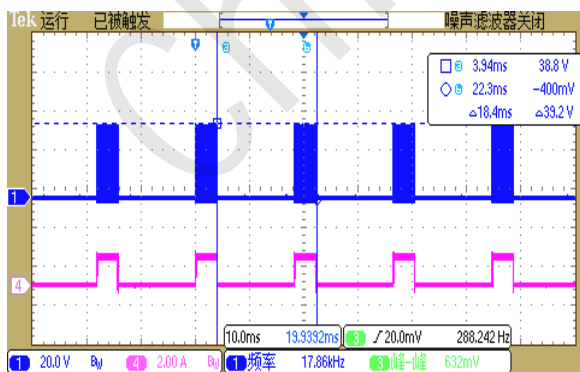

短路 IN:24V

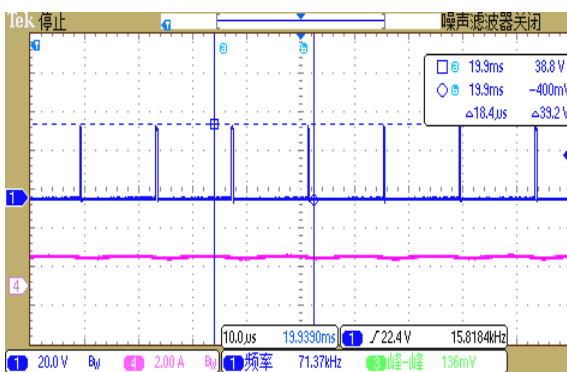

短路 IN:24V



MT2445AD 0.8A,40V Input,600kHz Synchronous Step-Down Converter

MT2445AD FUNCTIONAL BLOCK DIAGRAM

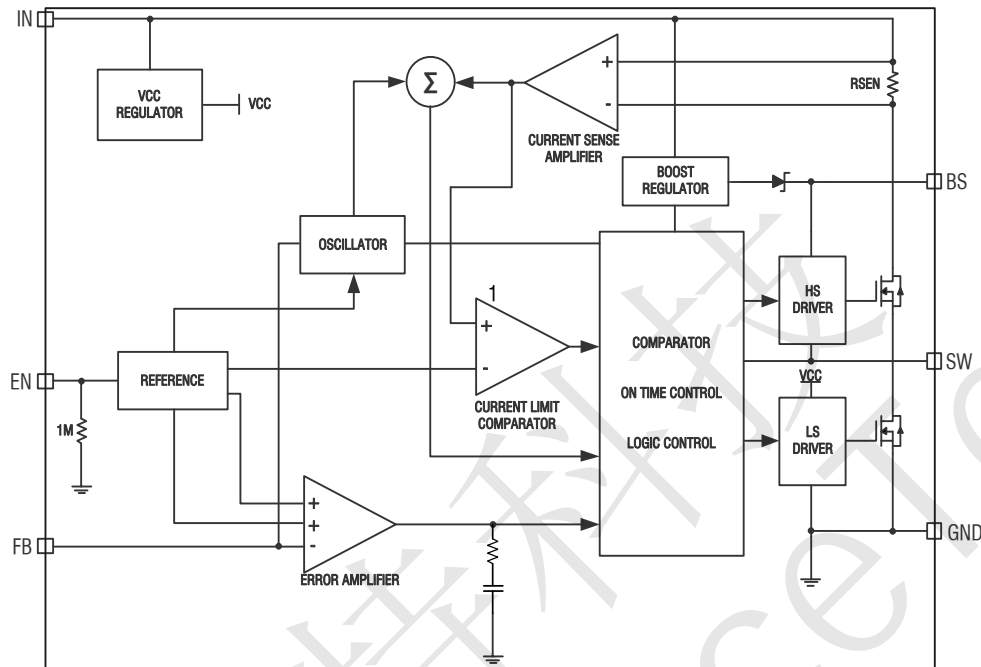

Figure 2. MT2445AD Block Diagram

MT2445AD FUNCTIONAL DESCRIPTION

Internal Regulator

The MT2445AD is a current mode step down DC/DC converter that provides excellent transient response with no extra external compensation components. This device contains an internal, low resistance, high voltage power MOSFET, and operates at a high 600K operating frequency to ensure a compact, high efficiency design with excellent AC and DC performance.

Error Amplifier

The error amplifier compares the FB pin voltage with the internal FB reference (V_{FB}) and outputs a current proportional to the difference between the two. This output current is then used to charge or discharge the internal compensation network to form the COMP voltage, which is used to control the power MOSFET current. The optimized internal compensation network minimizes the external

component counts and simplifies the control loop design.

Internal Soft-Start

The soft-start is implemented to prevent the converter output voltage from overshooting during startup. When the chip starts, the internal circuitry generates a soft-start voltage (SS) ramping up from 0V to 0.8V. When it is lower than the internal reference (REF), SS overrides REF so the error amplifier uses SS as the reference. When SS is higher than REF, REF regains control. The SS time is internally fixed to 1 ms.

Over-Current-Protection

The MT2445AD has cycle-by-cycle over current limit when the inductor current peak value exceeds the set current limit threshold. This protection mode is especially useful when the



MT2445AD 0.8A,40V Input,600kHz Synchronous Step-Down Converter

output is dead-short to ground. The average short circuit current is greatly reduced to alleviate the thermal issue and to protect the regulator.

Startup and Shutdown

If both VIN and EN are higher than their appropriate thresholds, the chip starts. The reference block starts first, generating stable reference voltage and currents, and then the internal regulator is enabled. The regulator

provides stable supply for the remaining circuitries. Three events can shut down the chip: EN low, VIN low and thermal shutdown. In the shutdown procedure, the signaling path is first blocked to avoid any fault triggering. The COMP voltage and the internal supply rail are then pulled down. The floating driver is not subject to this shutdown command.

MT2445AD APPLICATIONS INFORMATION

Setting the Output Voltage

The external resistor divider is used to set the output voltage (see Typical Application on page 1). The feedback resistor R1 also sets the feedback loop bandwidth with the internal compensation capacitor. Choose R1 to be around 100kΩ for optimal transient response. R2 is then given by:

$$R2 = \frac{R1}{\frac{V_{OUT}}{V_{FB}} - 1}$$

Inductor Selection

A 4.7μH to 22μH inductor with a DC current rating of at least 25% percent higher than the maximum load current is recommended for most applications. For highest efficiency, the inductor applications. For highest efficiency, the inductor DC resistance should be less than 15mΩ. For most designs, the inductance value can be derived from the following equation.

$$L = \frac{V_{OUT} \times (V_{IN} - V_{OUT})}{V_{IN} \times \Delta I_L \times f_{OSC}}$$

Where ΔI_L is the inductor ripple current. Choose inductor ripple current to be approximately 30% if the maximum load current, 1A. The maximum inductor peak current is:

$$I_{L(MAX)} = I_{LOAD} + \frac{\Delta I_L}{2}$$

DC resistance should be less than 15mΩ. For most designs, the inductance value can be derived from the following equation.

$$L = \frac{V_{OUT} \times (V_{IN} - V_{OUT})}{V_{IN} \times \Delta I_L \times f_{OSC}}$$

Where ΔI_L is the inductor ripple current. Choose inductor ripple current to be approximately 30% if the maximum load current, 1A. The maximum inductor peak current is:

$$I_{L(MAX)} = I_{LOAD} + \frac{\Delta I_L}{2}$$

Under light load conditions below 100mA, larger inductance is recommended for improved efficiency.

Under light load conditions below 100mA, larger inductance is recommended for improved efficiency.

Input Capacitor Selection

The input capacitor reduces the surge current drawn from the input and switching noise from the device. The input capacitor impedance at the switching frequency should be less than input source impedance to prevent high frequency switching current passing to the input. A low ESR input capacitor sized for maximum RMS current must be used. Ceramic capacitors with X5R or X7R dielectrics are highly recommended



MT2445AD 0.8A,40V Input,600kHz Synchronous Step-Down Converter

because of their low ESR and small temperature coefficients. A 10 μ F ceramic capacitor for most applications is sufficient. A large value may be used for improved input voltage filtering.

Output Capacitor Selection

The output capacitor (C_{OUT}) is required to maintain the DC output voltage. Ceramic, tantalum, or low ESR electrolytic capacitors are recommended. Low ESR capacitors are preferred to keep the output voltage ripple low. The output voltage ripple can be estimated by:

$$\Delta V_{OUT} = \frac{V_{OUT} \times (V_{IN} - V_{OUT})}{V_{IN} \times f_{OSC} \times L} \times \left(R_{ESR} + \frac{1}{8 \times f_{OSC} \times C_{OUT}} \right)$$

Where L is the inductor value and R_{ESR} is the equivalent series resistance (ESR) value of the output capacitor. In the case of ceramic capacitors, the impedance at the switching frequency is dominated by the capacitance. The output voltage ripple is mainly caused by the capacitance. For simplification, the output voltage ripple can be estimated by:

$$\Delta V_{OUT} = \frac{V_{OUT}}{8 \times f_{OSC}^2 \times L \times C_{OUT}} \times \left(1 - \frac{V_{OUT}}{V_{IN}} \right)$$

In the case of tantalum or electrolytic capacitors, the ESR dominates the impedance at the switching frequency. For simplification, the output ripple can be approximated to:

$$\Delta V_{OUT} = \frac{V_{OUT}}{f_{OSC} \times L} \times \left(1 - \frac{V_{OUT}}{V_{IN}} \right) \times R_{ESR}$$

The characteristics of the output capacitor also affect the stability of the regulation system. The MT2445AD can be optimized for a wide range of capacitance and ESR values.

PCB Layout Recommendations

PCB layout is very important to achieve stable operation. It is highly recommended to duplicate EVB layout for optimum performance. If change is necessary, please follow these guidelines and take Figure 3 for reference.

- Keep the path of switching current short and minimize the loop area formed by Input capacitor, high-side MOSFET and low-side MOSFET.
- Bypass ceramic capacitors are suggested to be put close to the VIN Pin.
- Ensure all feedback connections are short and direct. Place the feedback resistors and compensation components as close to the chip as possible.
- V_{OUT} , SW away from sensitive analog areas such as FB.
- Connect IN, SW, and especially GND respectively to a large copper area to cool the chip to improve thermal performance and long-term reliability.
- An example of 2-layer PCB layout is shown in Figure 3 for reference.

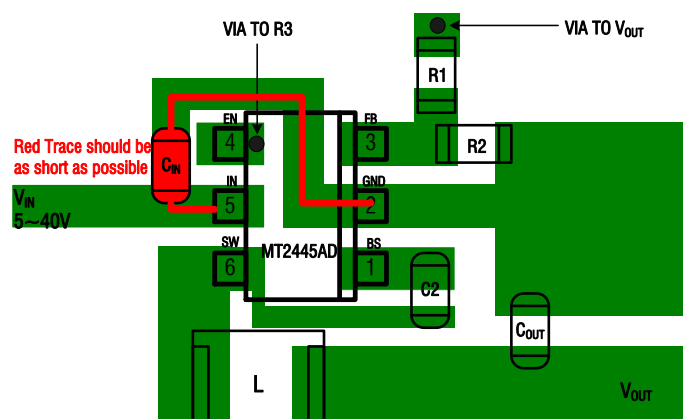

Figure 3. MT2445AD Suggested Layout



MT2445AD 0.8A,40V Input,600kHz Synchronous Step-Down Converter

MT2445AD PACKAGE DESCRIPTION

SOT23-6

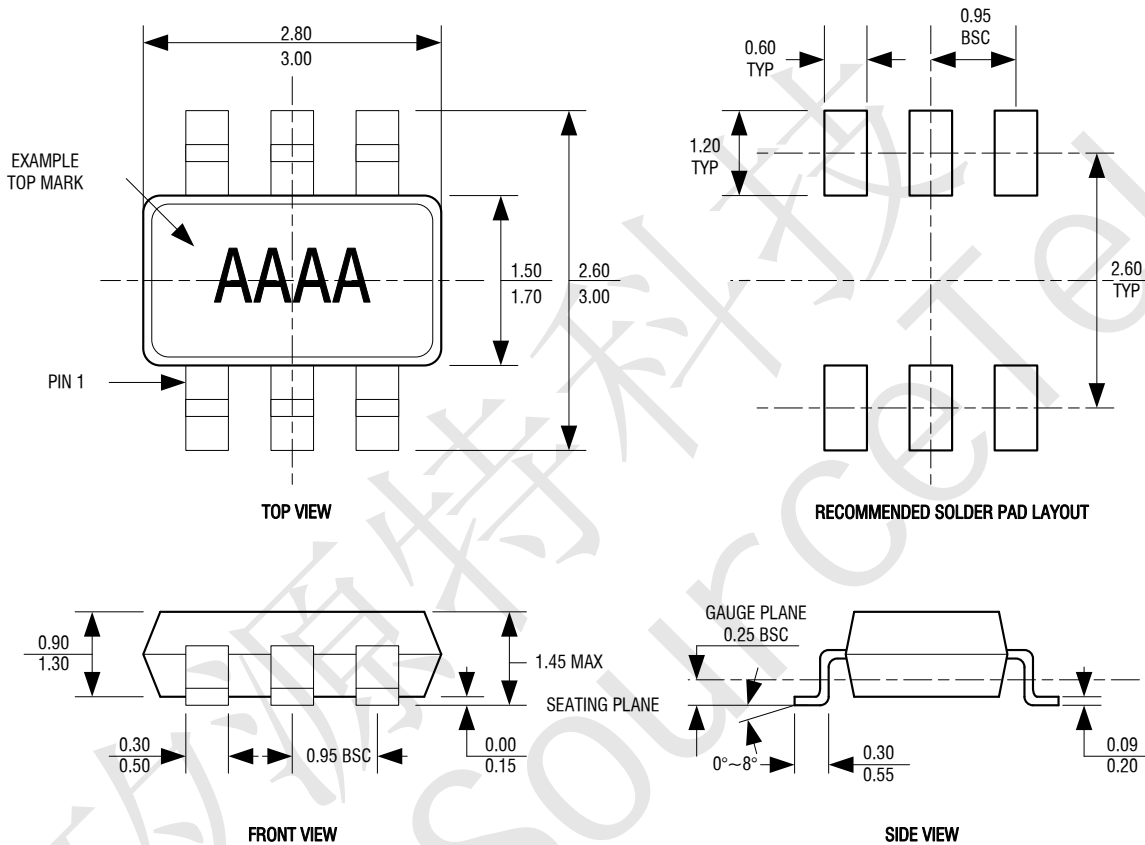

- NOTE:
1. DIMENSIONS ARE IN MILLIMETERS.
 2. DRAWING NOT TO SCALE.
 3. DIMENSIONS ARE INCLUSIVE OF PLATING.
 4. DIMENSIONS ARE EXCLUSIVE OF MOLD FLASH AND METAL BURR.



MT2445AD 0.8A,40V Input,600kHz Synchronous Step-Down Converter

IMPORTANT NOTICE

ShenZhen ChipSourceTek Technology Co.,Ltd reserve the right to make corrections, enhancements, improvements and other changes to its semiconductor products and services.

ShenZhen ChipSourceTek Technology Co.,Ltd is not responsible or liable for such altered documentation.

Information of third parties may be subject to additional restrictions.

ShenZhen ChipSourceTek Technology Co.,Ltd does not assume any responsibility for use of any its products for any particular purpose, nor does ShenZhen ChipSourceTek Technology Co.,Ltd assume any liability arising out of the application or use of any its products or circuits.

矽源特科技
ChipSourceTek