



P-Channel Enhancement Mode Power MOSFET

Description

The PE7408DS uses advanced trench technology to provide excellent $R_{DS(ON)}$ and low gate charge. It can be used in a wide variety of applications.

General Features

- $V_{DS} = -40V, I_D = -8A$
- $R_{DS(ON)} < 22m\Omega @ V_{GS} = -10V$
- $R_{DS(ON)} < 32m\Omega @ V_{GS} = -4.5V$
- High Power and current handing capability
- Lead free product is acquired
- Surface Mount Package

Application

- DC-DC converter
- Load switch
- Power management

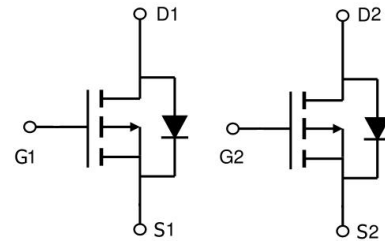

Schematic diagram

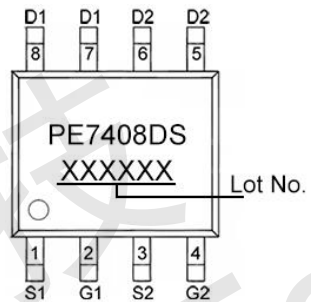

Marking and pin assignment

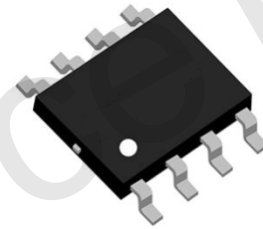

SOP-8

Absolute Maximum Ratings (TA=25°C unless otherwise noted)

| Parameter | Symbol | Rating | Unit |
|--|----------------|------------|------|
| Drain-Source Voltage | V_{DS} | -40 | V |
| Gate-Source Voltage | V_{GS} | ± 20 | V |
| Drain Current-Continuous | I_D | -8 | A |
| Drain Current-Continuous (TA=70°C) | I_D | -6 | A |
| Pulsed Drain Current (Note 1) | I_{DM} | -32 | A |
| Maximum Power Dissipation | P_D | 2 | W |
| Operating Junction and Storage Temperature Range | T_J, T_{STG} | -55 To 150 | °C |

Thermal Characteristic

| | | | |
|--|-----------------|------|------|
| Thermal Resistance, Junction-to-Ambient (Note 2) | $R_{\theta JA}$ | 62.5 | °C/W |
|--|-----------------|------|------|



Electrical Characteristics (TA=25°C unless otherwise noted)

| Parameter | Symbol | Condition | Min | Typ | Max | Unit |
|---|--------------|---|------|------|-----------|------------|
| Off Characteristics | | | | | | |
| Drain-Source Breakdown Voltage | BV_{DSS} | $V_{GS}=0V, I_D=-250\mu A$ | -40 | - | - | V |
| Zero Gate Voltage Drain Current | I_{DSS} | $V_{DS}=-40V, V_{GS}=0V$ | - | - | -1 | μA |
| Gate-Body Leakage Current | I_{GSS} | $V_{GS}=\pm 20V, V_{DS}=0V$ | - | - | ± 100 | nA |
| On Characteristics (Note 3) | | | | | | |
| Gate Threshold Voltage | $V_{GS(th)}$ | $V_{DS}=V_{GS}, I_D=-250\mu A$ | -1.1 | -1.7 | -2.5 | V |
| Drain-Source On-State Resistance | $R_{DS(on)}$ | $V_{GS}=-10V, I_D=-8A$ | - | 16 | 22 | m Ω |
| | | $V_{GS}=-4.5V, I_D=-5A$ | - | 23 | 32 | m Ω |
| Forward Transconductance | g_{FS} | $V_{DS}=-5V, I_D=-5A$ | 15 | - | - | S |
| Dynamic Characteristics (Note 4) | | | | | | |
| Input Capacitance | C_{iss} | $V_{DS}=-20V, V_{GS}=0V,$ $F=1.0MHz$ | - | 2050 | - | pF |
| Output Capacitance | C_{oss} | | - | 140 | - | pF |
| Reverse Transfer Capacitance (Note 4) | C_{rss} | | - | 130 | - | pF |
| Switching Characteristics | | | | | | |
| Turn-on Delay Time | $t_{d(on)}$ | $V_{DS}=-20V, R_L=1.6\Omega,$ $V_{GS}=-10V, R_G=3\Omega$ | - | 10 | - | nS |
| Turn-on Rise Time | t_r | | - | 24 | - | nS |
| Turn-Off Delay Time | $t_{d(off)}$ | | - | 40 | - | nS |
| Turn-Off Fall Time | t_f | | - | 9 | - | nS |
| Total Gate Charge | Q_g | $V_{DS}=-20V, I_D=-8A,$ $V_{GS}=-10V$ | - | 45 | - | nC |
| Gate-Source Charge | Q_{gs} | | - | 6 | - | nC |
| Gate-Drain Charge | Q_{gd} | | - | 11 | - | nC |
| Drain-Source Diode Characteristics | | | | | | |
| Diode Forward Voltage (Note 3) | V_{SD} | $V_{GS}=0V, I_S=-1A$ | - | - | -1.2 | V |
| Diode Forward Current (Note 2) | I_S | | - | - | -2.5 | A |

Notes:

1. Repetitive Rating: Pulse width limited by maximum junction temperature.
2. Surface Mounted on FR4 Board, $t \leq 10$ sec.
3. Pulse Test: Pulse Width $\leq 300\mu s$, Duty Cycle $\leq 2\%$.
4. Guaranteed by design, not subject to product.



Typical Electrical and Thermal Characteristics

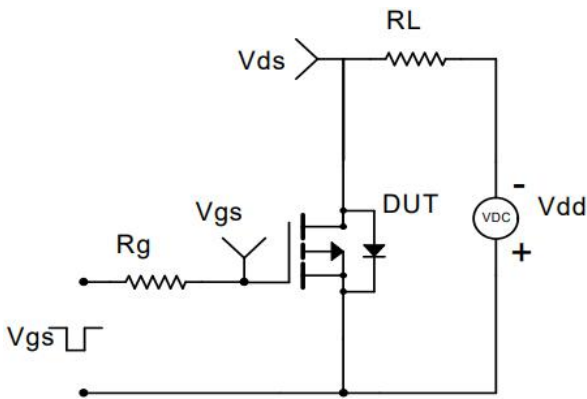

Figure 1 Switching Test Circuit

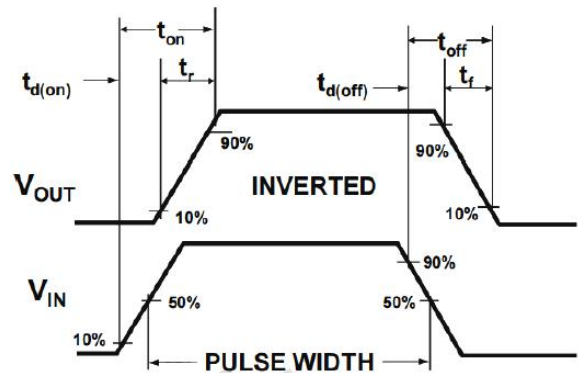
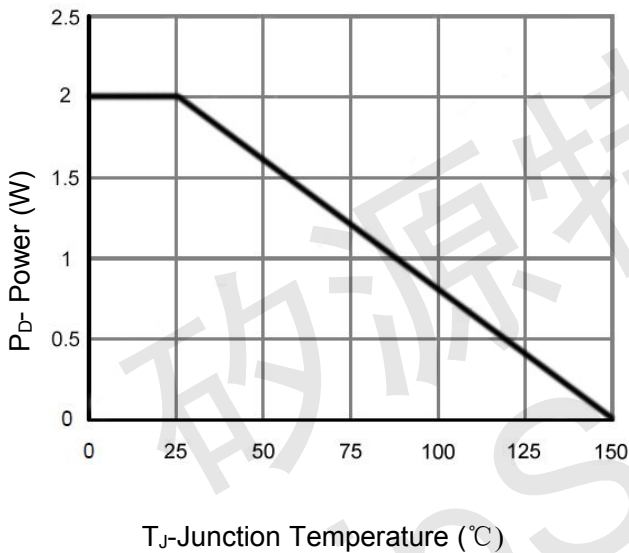
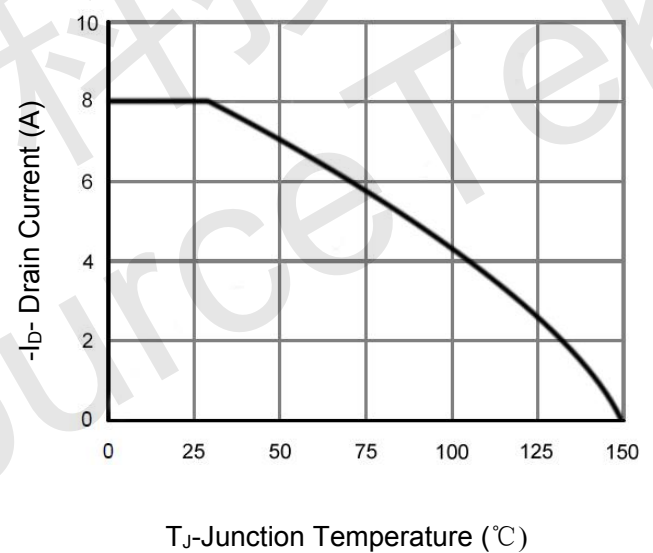

Figure 2 Switching Waveform



T_J-Junction Temperature (°C)

Figure 3 Power De-rating



T_J-Junction Temperature (°C)

Figure 4 Drain Current

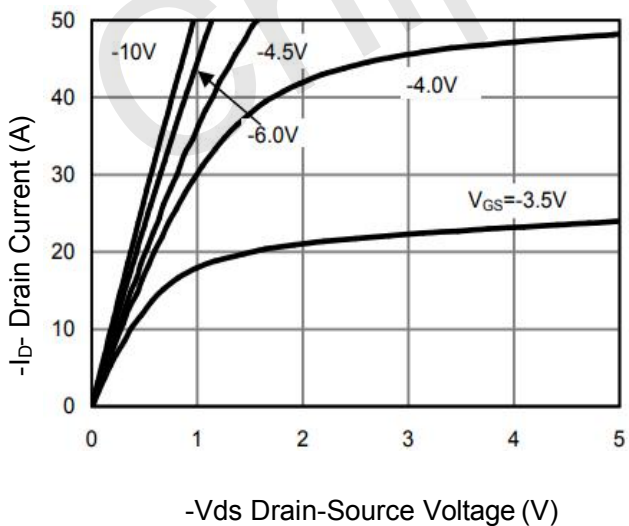

-V_{DS} Drain-Source Voltage (V)

Figure 5 Output Characteristics

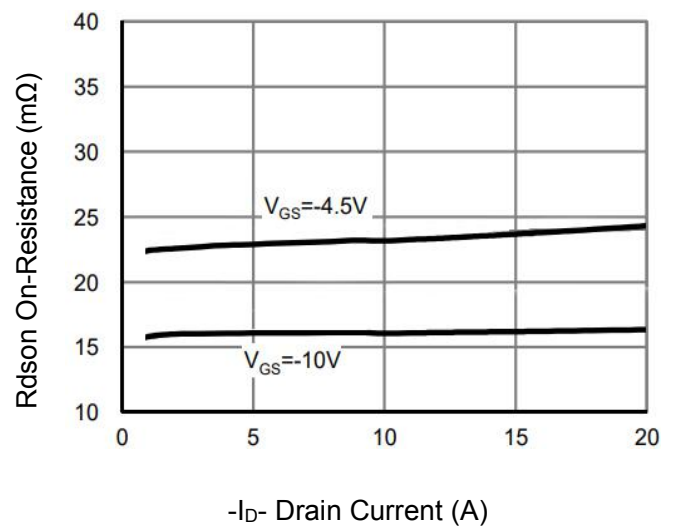

-I_D- Drain Current (A)

Figure 6 Rdson vs Drain Current

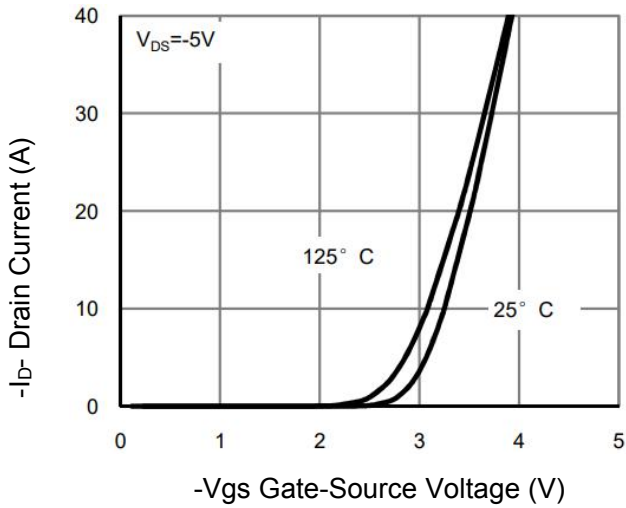

Figure 7 Transfer Characteristics

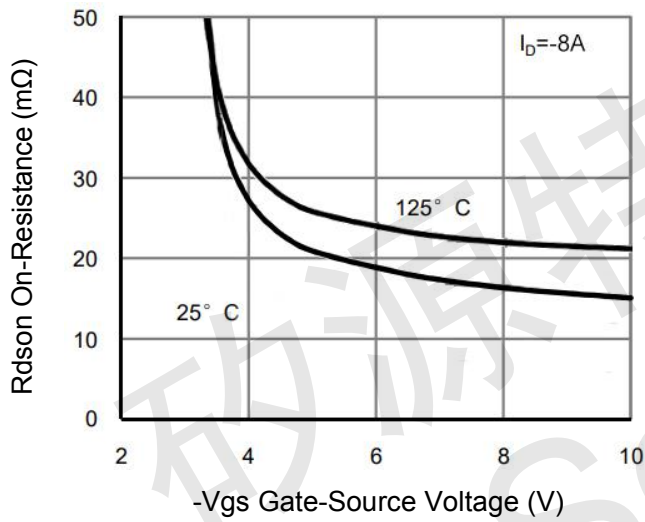

Figure 9 Rdson vs Vgs

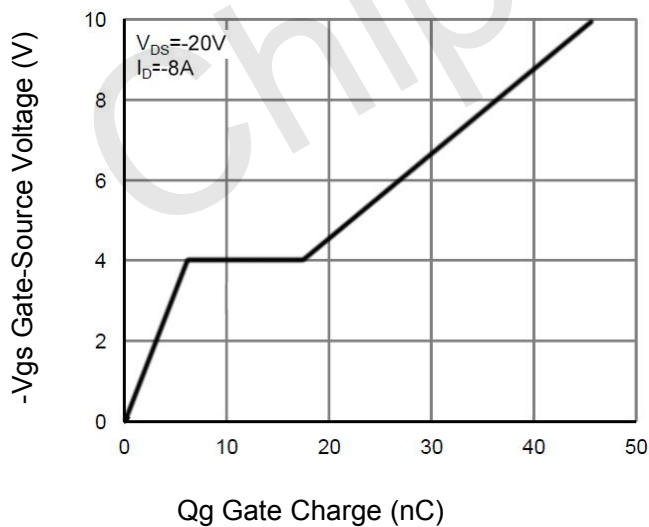

Figure 11 Gate Charge

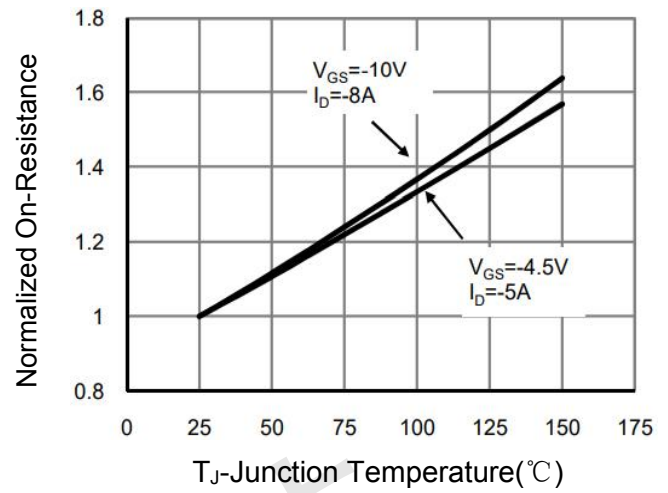

Figure 8 Rdson vs Junction Temperature

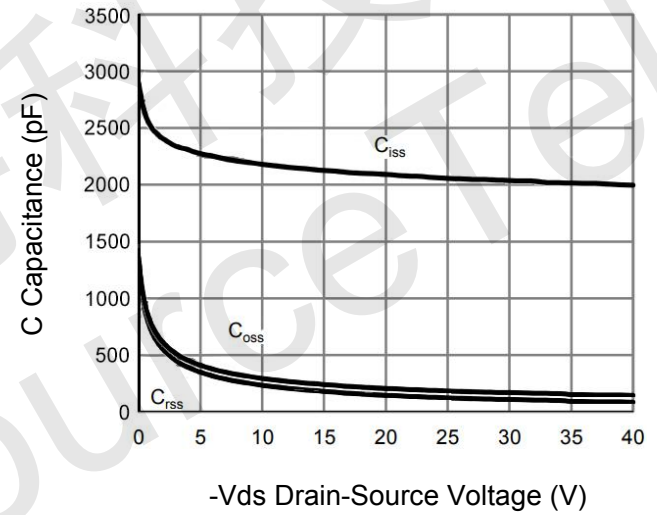

Figure 10 Capacitance vs Vds

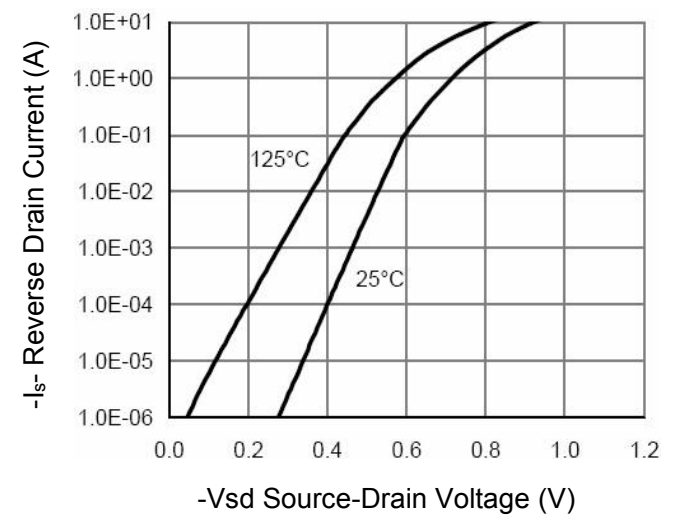

Figure 12 Source- Drain Diode Forward

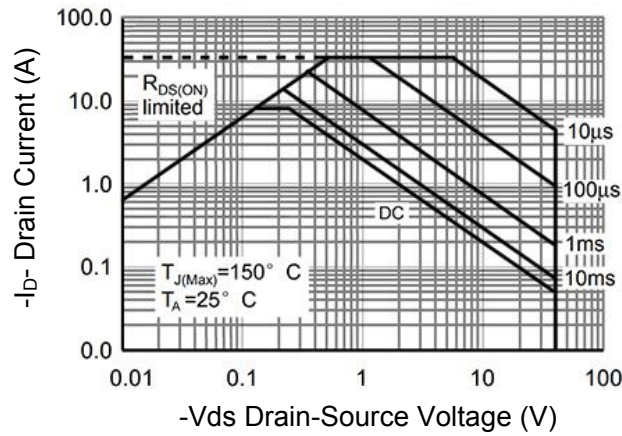

Figure 13 Safe Operation Area

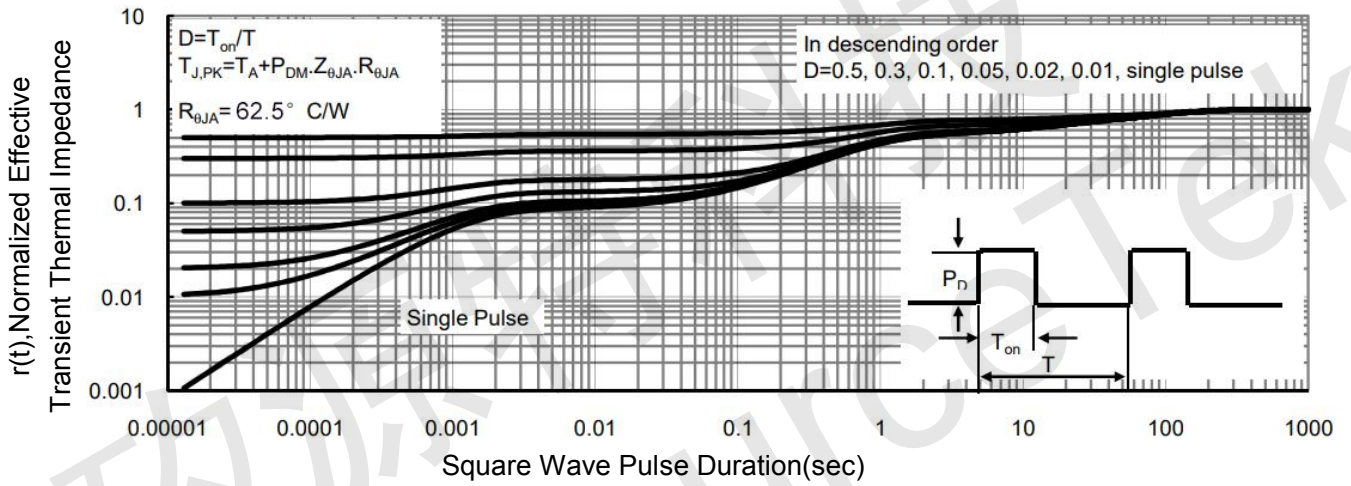
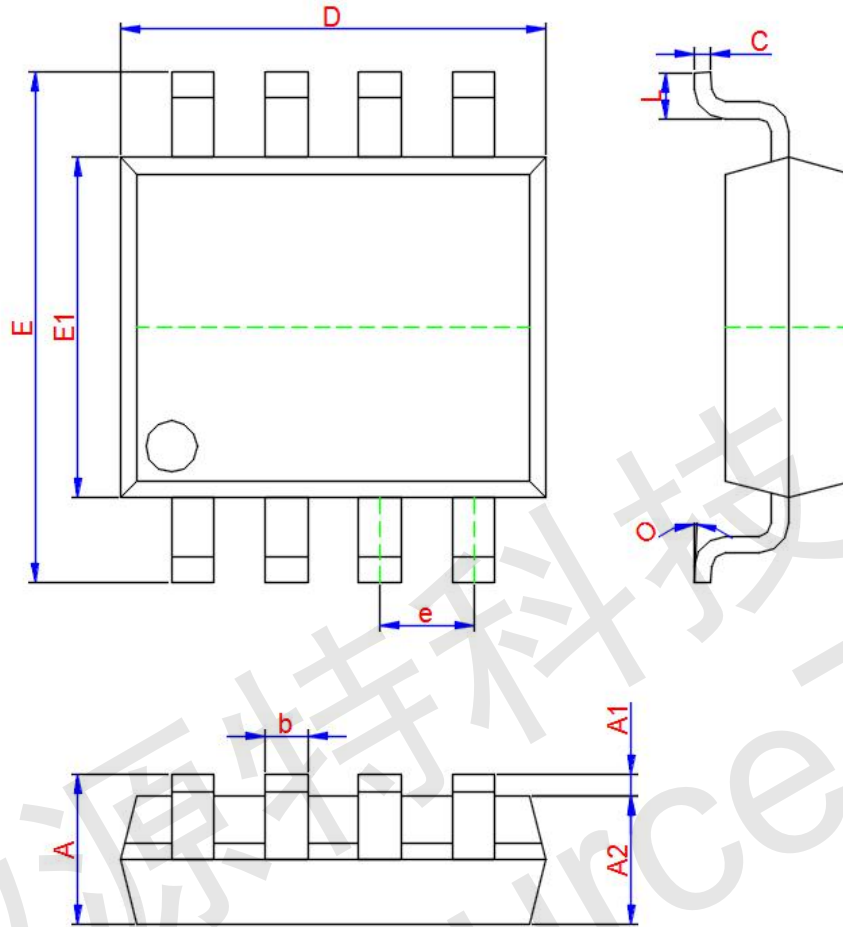

Figure 14 Normalized Maximum Transient Thermal Impedance



SOP-8 Package Information



| Symbol | Dimensions In Millimeters | | |
|--------|---------------------------|-------|-------|
| | Min. | Typ. | Max. |
| A | 1.350 | 1.550 | 1.750 |
| A1 | 0.100 | 0.175 | 0.250 |
| A2 | 1.350 | 1.450 | 1.550 |
| b | 0.330 | 0.420 | 0.510 |
| c | 0.170 | 0.210 | 0.250 |
| D | 4.700 | 4.900 | 5.100 |
| e | 1.270 TYP. | | |
| E | 5.800 | 6.000 | 6.200 |
| E1 | 3.750 | 3.900 | 4.050 |
| L | 0.400 | 0.835 | 1.270 |
| O | 0° | 4° | 8° |